

# DuroZone®

## INSTALLATION INSTRUCTIONS

### NSPRD024 SPRING RETURN DAMPER (24 volt)



DuroZone NSPRD024 Spring Return Dampers can be configured for either Spring Open or Spring Closed operation. The Spring Closed side is identified S.C. or N.C. (normally closed) and the Spring Open side is identified S.O. or N.O. (normally open). All NSPRD024 dampers are shipped in the Spring Open (S.O.) position. To change to Spring Closed (S.C.) operation, simply unscrew the allen bolt and remove the motor. Then close the damper blade and reinstall the motor on the opposite side and screw the allen bolt onto the shaft.

## MOTOR LEAD IDENTIFICATION

Yellow and Orange leads: 24 volt input AC Only

### - IMPORTANT -

This motor is designed for use with 24 VAC power source.

### - WIRE ACCORDING TO LOCAL CODE -

#### TYPICAL WIRING

To Control Panel Part# 35226 (SMZ2SW)  
35227 (SMZ3SW) /35229 (SMZAC)  
35235(JTZHP) /35236 (ED3) /35237 (ED4)

**NOTE:** On SMZ Panels it is recommended to leave the damper switches on the control panel in the open position.

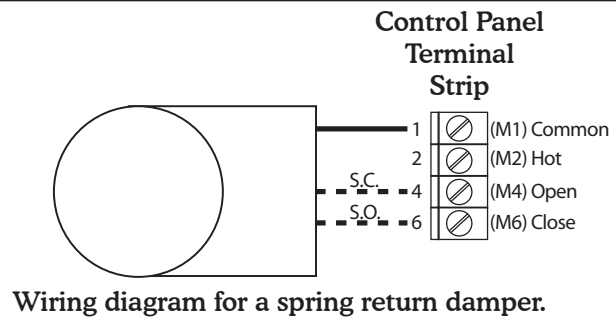

## Spring Return Motor Operation

Energizing the Yellow and Orange leads with 24 volts will activate the damper. Removing power from the Yellow and Orange leads will cause the damper to return to original position.

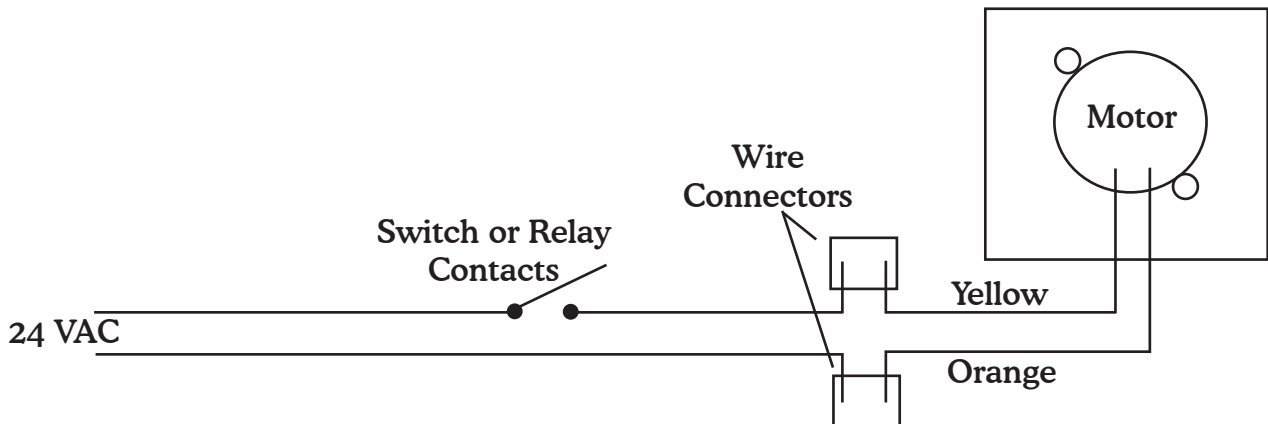

Duro Dyne East • Bay Shore, NY 11706 • Phone: 631-249-9000 • Fax: 631-249-8346  
Duro Dyne Midwest • Fairfield, OH 45011 • Phone: 513-870-6000 • Fax: 513-870-6005  
Duro Dyne West • Santa Fe Springs, CA 90670 • Phone: 562-926-1774 • Fax: 562-926-5778  
Duro Dyne Canada • Lachine • Quebec • Canada • Phone: 514-422-9760 • Fax: 514-636-0328

©2015 Duro Dyne Corporation  
Printed in USA 06/2015  
BI035405

**ALL DuroZone DAMPERS FEATURE:**  
• 5 year limited warranty • Controlled bypass • Maintenance free operation • 100% factory testing • Screwless terminals • Custom dampers and special controls are available on request.