

# DuroZone®

## INSTALLATION INSTRUCTIONS

### MMB SERIES MULTI-BLADE DAMPER SPRING RETURN MID-TORQUE MOTOR

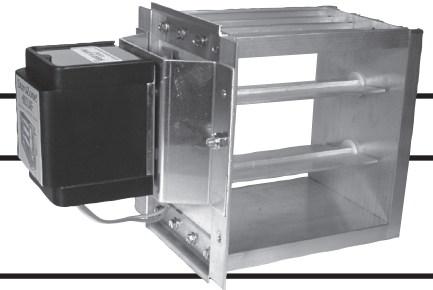

#### INSTALLATION IN DUCT

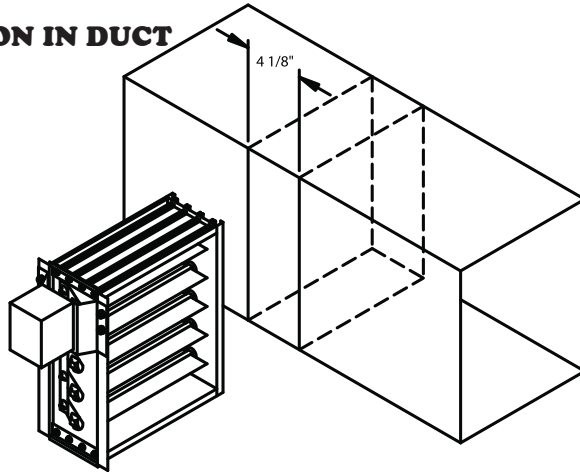

1. Cut 4 1/8" wide slot into side of sheet metal duct.
2. Slide damper into duct work.
3. Secure by screwing the damper into the ductwork. (Screws Provided)

#### TYPICAL WIRING

To Control Panel Part# 35226 (SMZ2SW)  
35227 (SMZ3SW) /35229 (SMZAC)  
35235(JTZHP) /35234 (RED)

Wiring diagram for a spring return damper that without power is normally open (spring open).

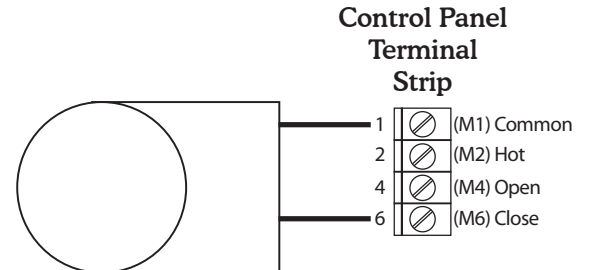

**NOTE:** On SMZ Panels it is recommended to leave the damper switches on the control panel in the open position.

### MOTOR LEAD IDENTIFICATION

Yellow and Orange leads: 24 volt input AC Only

**- IMPORTANT -**

This motor is designed for use with 24 Volt VAC power source.

**- WIRE ACCORDING TO LOCAL CODE -**

#### Spring Open Damper Motor Operation

Energizing the Yellow and Orange leads with 24 volts will close the damper. Removing power from the Yellow and Orange leads will cause the damper to return to a fully open position.

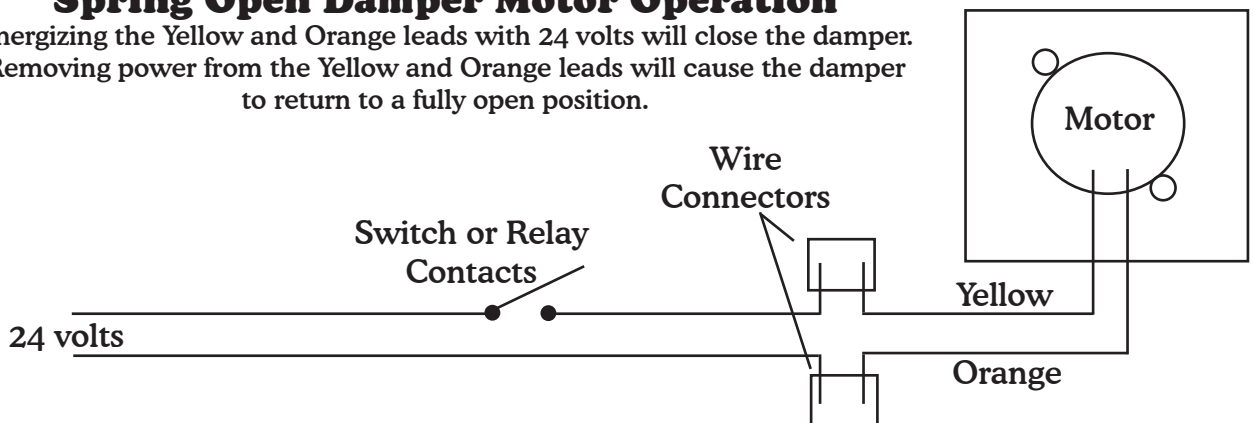

Duro Dyne East • Bay Shore, NY 11706 • Phone: 631-249-9000 • Fax: 631-249-8346  
Duro Dyne Midwest • Fairfield, OH 45011 • Phone: 513-870-6000 • Fax: 513-870-6005  
Duro Dyne West • Fontana, CA 92337 • Phone: 562-926-1774 • Fax: 562-926-5778  
DuroDyne Canada • Lachine • Quebec • Canada • Phone: 514-422-9760 • Fax: 514-636-0328

©2014 Duro Dyne Corporation  
Printed in USA 12/2014  
B1050001

**ALL DuroZone DAMPERS FEATURE:**  
• 3 year limited warranty • Controlled bypass •  
Maintenance free operation • 100% factory test-  
ing • Screwless terminals • Custom dampers  
and special controls are available on request.