

# CCD110 PINSPOTTER ITEM # 27120



## GENERAL DESCRIPTION

The CCD110, Capacitor Discharge Welder, is designed for the convenience and comfort of the operator. It is powered by a 110 volt power source so it is ideal for smaller shops and light industrial applications. It will weld pins from 1/2" to 4" long onto steel from 26 to 20 gauge. Its portability on the job, enhanced by its adjustable shoulder strap, makes the CCD110 a smart choice for insulation applications. The CCD110 also features a stud capacity of up to 1/4" steel and stainless steel for enhanced versatility.

The CCD110 measures 10 5/8" x 9 11/16" x 6 7/8" (270 mm x 246 mm x 174 mm) and is lightweight at 10.5 lbs (4.76 kg) — the lightest unit available. Its tough, corrosion-proof plastic case is made from an ultra-high-impact co-polymer that provides extra insulation and resists rusting and denting in even the most demanding work environments. The demand fan and thermal shut-down protection also prevent possible damage to the unit.

The CCD110 allows you to auto-select the type of welding on the spot, by supporting both gap and contact welding. This automatic, double capability performs the work of two tools in one! The CCD110 ensures safe operations for all users. A microprocessor conducts continuous system checks for component fault and controls unit shut-down. Dual weld SCRs provide maximum weld current restriction safety. Operator lights clearly indicate status and the included manual simplifies error code look-up.

## FEATURES

- The most compact and lightweight welding unit available in the industry
- Designed to support both gap and contact welding methods
- Rugged construction stands up to even the roughest treatment and harshest environments
- Highly flexible design can be used in a wide range of industrial and insulation applications
- Rapid operation delivers an incredible 24 continuous welds per minute
- Ground Fault Interruption (GFI) protection — an industry first



For best performance,  
use genuine Duro Dyne insulation fasteners



RIB  
PINS



SLOPE  
PINS



TARGET  
PINS



ECONO-  
POINT PINS



GOLD  
SEAL PINS

MACHINERY DIVISION  
© 2016 Duro Dyne Corporation  
Printed in USA 9/8/2016  
BC039409



## **CAPACITY SPECIFICATIONS**

**Charge Time:** < 3 seconds to maximum charge  
**Duty Cycle:** 24 welds/minute at maximum voltage

## **OPERATIONAL SPECIFICATIONS**

- Indicator Lights (5)
- Resettable Breaker
- Fan Thermal Switch
- Safety Shutdowns
- 7 Segment Voltage/Message Display



**Indicator Lights**

## **ELECTRICAL SPECIFICATIONS**

	<b>Incoming</b>	<b>Outgoing</b>
Voltage	115 VAC	40 - 150 VDC
Current	15/10 A	3,000 - 9,000 A
Hertz	60	DC
Capacitance		66,000 $\mu$ f



**Will weld pins from 1/2" to 4" long  
onto steel from 26 to 20 gauge.**

## **DIMENSIONS**

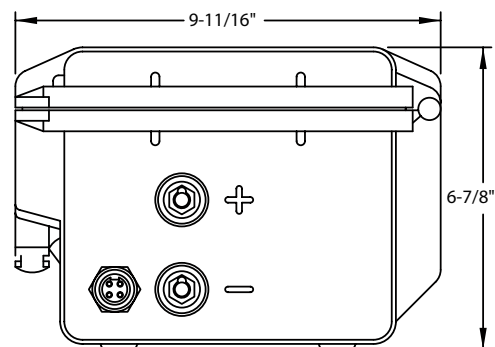
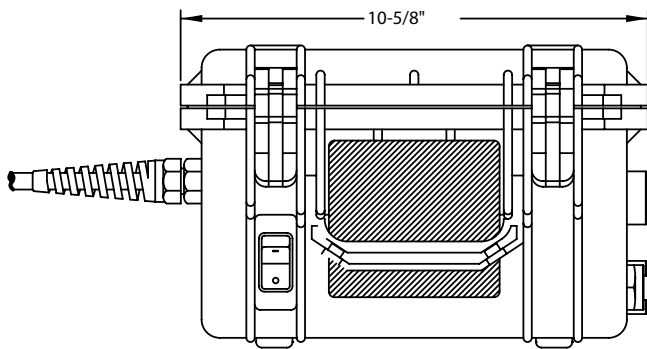

**Duro Dyne East Division, Bay Shore, NY**  
**Duro Dyne Midwest Division, Hamilton, OH**  
**Duro Dyne West Division, Fontana, CA**  
**Duro Dyne Canada, Lachine, Quebec, Canada**

**631-249-9000 Fax: 631-249-8346**  
**513-870-6000 Fax: 513-870-6005**  
**562-926-1774 Fax: 562-926-5778**  
**514-422-9760 Fax: 514-636-0328**

**www.durodyne.com E-mail: durodyne@durodyne.com**